

STUDY OF BROADENING IN A COMBINED PROCESS

“ROLLING - PRESSING” USING AN EQUAL-CHANNEL STEP DIE

Abdrakhman Naizabekov¹, Sergey Lezhnev¹, Evgeniy Panin¹, Toncho Koinov²

¹Karaganda state industrial University, Temirtau,
Republic of Kazakhstan,
E-mail: sergey_legnev@mail.ru

²Department of Physical Metallurgy and Thermal Equipment,
University of Chemical Technology and Metallurgy,
8 Kliment Ohridski, Sofia 1756, Bulgaria,
E-mail: toni309@koinov.com

Received 15 December 2014

Accepted 06 April 2015

ABSTRACT

This article is devoted to studying of broadening in a combined process “rolling - pressing”, using an equal-channel step die. In laboratory conditions an experiment for implementation of this process, using smooth rolls and three dies with different values of angle of the channels junction was done. A formula, which allows finding the value of broadening in the combined process “rolling-pressing”, using an equal-channel step die was obtained. This formula is applicable for any value of the angle of the channel’s junction.

Keywords: combined process, “rolling-pressing”, equal-channel step die broadening.

INTRODUCTION

The combined process “rolling-pressing” is one of the most promising ways to obtain high-strength metal, which is based on the use of reserve forces and friction on the contact surface of the metal with rotating rolls [1].

At the “Metal forming” department of the Karaganda state industrial university a new combined method of rolling and pressing using equal-channel step die was developed and proposed. It, in comparison with conventional pressing in this die [2], provides continuity of the process and removes restrictions on the billets size (Fig. 1).

The essence of the proposed method of deformation is described hereunder. The billet, pre-heated to the temperature of the beginning of deformation, is fed to the rolling rolls, which due to the contact friction forces, take it into the mouth of the rolls, and on the exit push

through channels of the equal-channel step die. When the billet is completely out of equal-channel step die, it is captured by a second pair of rolls, which also due to the contact friction forces, grip the workpiece into the mouth of the second pair of rolls and completely pull the billet from the equal-channel step die.

The advantage of this method is that the implementation of this combined process with the proposed scheme, ensures the continuity of the process, and removes restrictions on the billets size.

In [3] a comparative analysis of the process of “rolling-pressing” with an equal-channel step die using grooved and smooth rolls was done. It was found that the use of grooved rolls at a similar source of data allowed realizing the process of “rolling-pressing” with an equal-channel step die with a smaller angle of intersection, at a much lower compression. This will allow to get the metal with an ultrafine-grained structure in lower

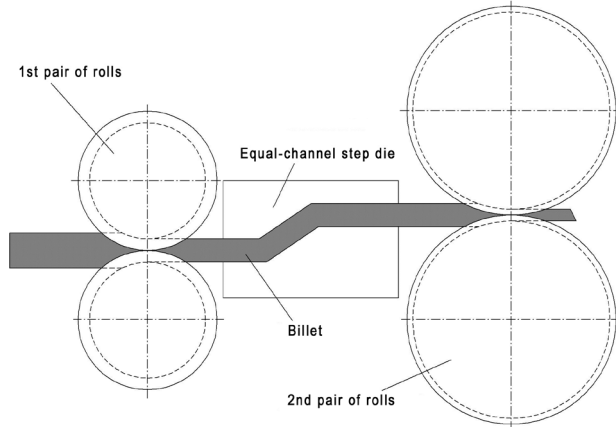

Fig. 1. The combined process “rolling - pressing” using an equal-channel step die.

number of cycles, due to greater intensification of shear deformation in the whole volume of the deformed billet in a single pass. Another undoubted advantage of using grooved rolls instead of the smooth ones is the opportunity to control the broadening of the billet during its deformation in the rolls.

However, because of the circumstances, a situation might arise when the use of grooved rolls, for one reason or another, will not be possible. For example, when one wants to deform the billets with different values of the initial width. Then, it using smooth rolls, one has to take into account the broadening of the workpiece, as by rolling in smooth rollers lateral metal flow is not limited to the walls of the caliber. This work is devoted to the study of this factor.

RESEARCH METHODS

Because after rolling in the rolls, the billet enters into the matrix channel, it is necessary that its width does not exceed the width of the input matrix channel. Otherwise the billet would be stuck at the input of matrix (Fig. 2).

Usually, for calculating of the broadening in rolling empirical formulas are used. The most well known formulas of Chekmarev, Celikov, Gubkin and Bahtinov are [4]:

Formula of Chekmarev:

$$\Delta b = \frac{2\Delta h \cdot b_{AV}}{(h_0 + h_1) \left[1 + (1 + \alpha) \left(\frac{b_{AV}}{R\alpha} \right)^n \frac{h_0 + h_1}{2h_1(1 + f_Y \cdot R\alpha / b_{AV})} \right]} \quad (1)$$

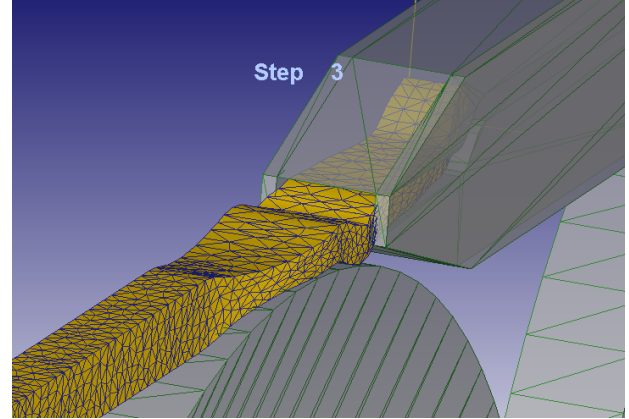

Fig. 2. Pressing out of billet.

where:

- h_0, h_1 - the initial and final thickness of billet, mm;
- b_{AV} - average width of billet, mm;
(it assumes that $b_{AV} \approx b_0$);
- Δh - reduction, mm;
- α - angle of capture, rad;
- R - radius of rolls, mm;
- $n=1$ when $b_0 < R\alpha$;
- $n=2$ when $b_0 > R\alpha$;
- f_Y - friction coefficient.

formula of Celikov:

$$\Delta b = \left(l_d - \frac{\Delta h}{2f_Y} \right) \left[2 \left(\frac{h_1}{\Delta h} \right)^2 \ln \frac{h_0}{h_1} - 2 \frac{h_1}{\Delta h} + 1 \right] \quad (2)$$

where $l_d = \sqrt{R \cdot \Delta h}$ - length of deformation zone, mm.

formula of Gubkin:

$$\Delta b = \left(1 + \frac{\Delta h}{h_0} \right) \left(f_Y \cdot l_d - \frac{\Delta h}{2} \right) \frac{\Delta h}{h_0} \quad (3)$$

formula of Bahtinov:

$$\Delta b = 1,15 \frac{\Delta h}{2h_0} \left(l_d - \frac{\Delta h}{2f_Y} \right) \quad (4)$$

Because in all of these formulas there are different components, the calculation results can be very different from each other. In this regard, a comparative analysis of the calculation of the broadening with all 4 formulas for the following initial data: $R = 100$ mm; $h_0 = 21$ mm; $b_0 = 20$ mm; $\Delta h = 7$ mm; $f_Y = 0,15$ was performed.

The radius of the rolls and the coefficient friction

Table 1. Theoretical determination of the broadening.

Variable parameter	Constant initial parameters	Chekmarev	Celikov	Gubkin	Bahtinov
Initial parameters: $R=100$ mm; $h_0=21$ mm; $b_0=20$ mm; $\Delta h=7$ mm; $f_y=0,15$		4,01	0,76	0,21	0,59
$R=120$ mm	$b_0=20$ mm	4,26	1,37	0,37	1,08
$R=140$ mm	$\Delta h=7$ mm	4,47	1,94	0,53	1,53
$R=80$ mm	$f_y=0,15$	3,71	0,08	0,02	0,06
$R=60$ mm		3,32	-0,69	-0,18	-0,54
$b_0=l_d=26,457$ mm	$R=100$ mm	4,46	imp	imp	imp
$b_0 < l_d=18$ mm	$\Delta h=7$ mm	3,83	imp	imp	imp
$b_0 > l_d=30$ mm	$f_y=0,15$	4,31	imp	imp	imp
$b_0 \gg l_d=40$ mm		3,74	imp	imp	imp
$b_0 \ll l_d=12$ mm		3,12	imp	imp	imp
$\Delta h=5$ mm	$R=100$ mm	2,59	0,96	0,25	0,78
$\Delta h=3$ mm	$b_0=20$ mm	1,23	0,72	0,18	0,62
$\Delta h=10$ mm	$f_y=0,15$	6,33	-0,62	-0,18	-0,46
$\Delta h=15$ mm		9,91	-6,77	-2,07	-4,63
$f_y=0,05$	$R=100$ mm	3,77	-10,61	-0,96	-8,34
$f_y=0,1$	$b_0=20$ mm	3,89	-2,08	-0,38	-1,64
$f_y=0,2$	$\Delta h=7$ mm	4,12	2,18	0,79	1,72
$f_y=0,25$		4,22	3,04	1,38	2,38

*“imp” means that in these formulas it is impossible to use value of initial width.

were taken in relation to mill DUO, located in our university laboratories.

In addition to the calculation of the broadening with the above initial data varying of the various geometrical and technological factors: radius of the rolls, coefficient friction, initial width of the billets and absolute value of reduction, was conducted. The variation was performed by increasing or decreasing one of the input parameters with the rest of the parameters kept at the same. The results of the calculations are given in Table 1.

As can be seen from Table 1, the calculation results for all 4 formulas when variation of the main factors affects the broadening is conducted, are very different from each other, suggesting the need for identifying formulas, calculation results of which will be close to the experimental values.

LABORATORY EXPERIMENT

For studying the broadening in the combined process “rolling-pressing” a laboratory experiment, with three

equal-channel step dies was done (Fig. 3).

All three dies have a similar structure and differ only in the angle of intersection of the channels (angle X in Fig. 3). In the first die channels intersect at an angle of 135 degrees, in the second - at an angle of 145 degrees, in the third - at an angle of 155 degrees. The lead samples were made with sizes:

Group 1: $h \cdot b \cdot l = 11,5'25'150$ mm

Group 2: $h \cdot b \cdot l = 11,5'16'150$ mm

Group 3: $h \cdot b \cdot l = 9,5'25'150$ mm

Group 4: $h \cdot b \cdot l = 9,5'16'150$ mm

Group 5: $h \cdot b \cdot l = 7,5'25'150$ mm

Group 6: $h \cdot b \cdot l = 7,5'16'150$ mm

The number of samples in each group was equal to 12 pcs. The small range of initial thickness is due to the fact that the mill, on which the experiment was conducted had rolls with a diameter of 100 mm, which did not allow to deform blanks with a larger thickness, because of limitations on the angle of grip.

Before the experiment, for each sample in five points measurements of the initial thickness and width

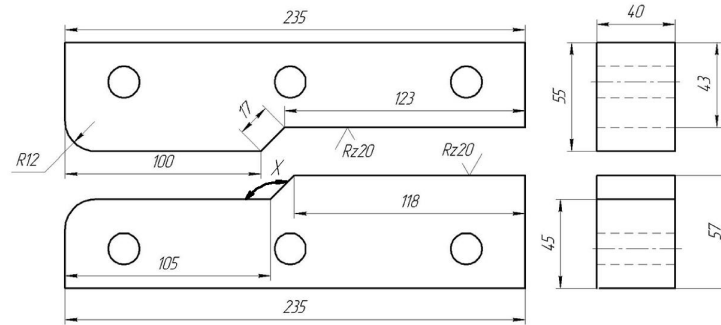

Fig. 3. An equal-channel step die.

were made, then their average values for each group were determined. The deformation of the samples was produced in two stages. At the first stage, three samples from each group were simply rolled, and after rolling measurements were made in five points of the thickness and width. Then the averaged values were found. At the second stage, the die was set at the exit of the rolls and rolled the other three samples so that the metal, after leaving the rolls, came into the die channel. Rolling was carried out as before, until there was no slipping of the workpiece in the rolls. After that, the rolls were separated, the die was removed from the mill and the deformed workpiece was removed from the die. Next, measurements of the thickness and width in five points were made and their average values were found.

RESULTS AND DISCUSSION

To identify the formula, which has calculation results of the broadening close to experimental values,

calculation by all 4 formulas for samples of each group was done. For this purpose, the radius of the rolls was set to 100 mm, the coefficient of friction during rolling was adopted aequal to 0.15. Then the deviation of the experimental values of the width after rolling from the theoretical values was calculated using the formula:

$$\Delta = \frac{B_{\text{EXP.ROLLING}} - B_{\text{THEORY}}}{B_{\text{EXP.ROLLING}}} \quad (5)$$

where:

$B_{\text{EXP.ROLLING}}$ - experimental value of width after rolling, mm;

B_{THEORY} - theoretical value of width, calculated by the formula, mm.

The results of the calculation are given in Table 2.

As can be seen from Table 2, for calculation of the broadening we need to use formula of Gubkin, because it gives a minimum deviation of the experimental values from the theoretical ones. However, for the calculation

Table 2. Theoretical and experimental values of the width of the samples.

Parameters	Theoretical and experimental values of the width of the samples, mm					Deviation of experimental values from theoretical, %			
	Chek	Cel	Gub	Bakh	EXP	Δ Chek	Δ Cel	Δ Gub	Δ Bakh
Group 1 $h_1=9$ mm	26,18	25,96	25,32	25,73	25,24	3,73	2,85	0,33	1,95
Group 2 $h_1=9$ mm	16,91	17,14	16,56	16,8	16,62	1,7	3,08	0,4	1,04
Group 3 $h_1=7$ mm	25,84	26,16	25,53	25,94	25,58	0,99	2,24	0,22	1,38
Group 4 $h_1=7$ mm	17,38	17,43	16,9	17,25	16,85	3,1	3,4	0,257	2,33
Group 5 $h_1=5$ mm	26,47	26,19	25,76	25,91	25,73	2,86	1,77	0,103	0,68
Group 6 $h_1=5$ mm	17,8	17,73	17,2	17,65	16,92	5,18	4,76	1,63	4,29

Table 3. Experimental values for the width in mm of the samples after rolling-pressing.

Paramaters	Angle 135 ⁰	Angle 145 ⁰	Angle 155 ⁰
Group 1 $h_1=9$ mm	27,7	27,2	26,5
	27,6	27	26,8
	27,9	27,1	26,9
Group 2 $h_1=9$ mm	17,4	16,9	16,8
	17,4	16,7	16,9
	17,5	16,8	16,6
Group 3 $h_1=7$ mm	27,4	26,7	26,2
	27,2	26,5	25,9
	27,5	26,8	26
Group 4 $h_1=7$ mm	18,2	17,9	17,4
	18,4	17,6	17,6
	18,5	18	17,1
Group 5 $h_1=5$ mm	27,6	26,8	25,6
	28	26,5	26
	27,8	26,7	25,8
Group 6 $h_1=5$ mm	18,9	17,9	17,3
	18,7	18	16,9
	18,9	18,1	16,9

of the broadening in the process of «rolling-pressing», this formula is unsuitable, because it does not take into account the influence of the back-pressure, created by the die. Therefore, it is necessary to include in this formula a coefficient that takes into account the influence of back-pressure.

In Table 3 are presented the values of the width of the samples after the implementation of the combined process of «rolling - pressing» for all three matrices.

Table 3 shows that with increasing of the angle of the channels intersection the broadening for each cross-section is reduced. This is because the larger angle of channels intersection decreases the influence of the back-pressure from the die side, and the broadening of the

metal goes down. With reducing the value of the angle of the channels intersection, the back-pressure from the die side increases, and the value of the broadening increases.

Fig. 4 presents a summary chart of the average values of the width before (b_0) and after (b_1) rolling, and after “rolling-pressing” for a die with an angle of 135 degrees (b_2), with an angle of 145 degrees (b_3), and with angle of 155 degrees (b_4).

In accordance with these values, for each die coefficients of the influence of the back-pressure for each group of samples were calculated according to the formula:

$$K = \frac{b_{RP}}{b_0}, \tag{6}$$

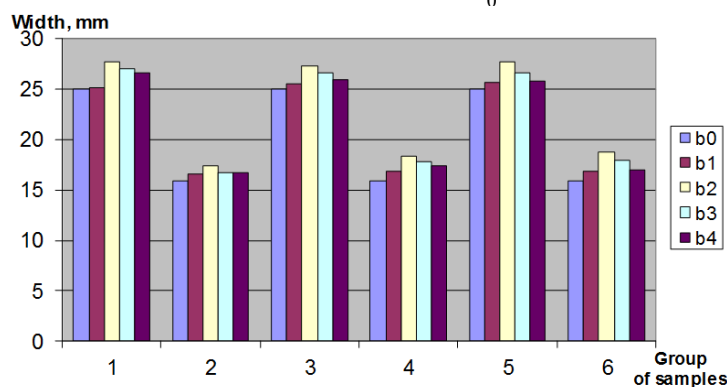

Fig. 4. Experimental values of widths of samples.

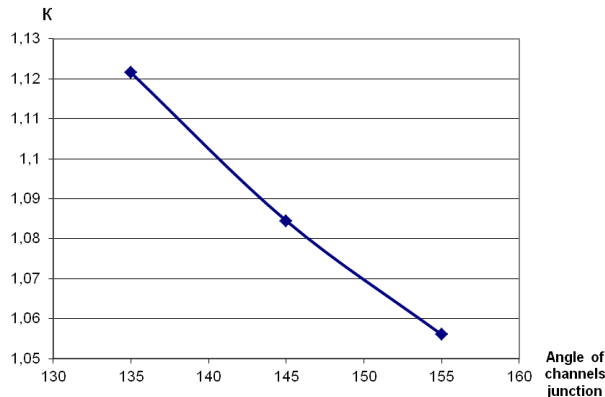

Fig. 5. Dependence of the back-pressure coefficient on the angle of the channels junction.

where:

b_{RP} - width of the samples after rolling-pressing, mm;

b_0 - initial width of the samples, mm.

Based on formula (6), the following data were obtained:

- for a die with the angle of channels intersection 135 degrees:

$$K_1 = 1,109; K_2 = 1,089; K_3 = 1,094; K_4 = 1,147, \\ K_5 = 1,112; K_6 = 1,176.$$

The average value of the coefficient:

$$\frac{1,109 + 1,089 + 1,094 + 1,147 + 1,112 + 1,176}{6} = 1,121$$

- for a die with the angle of channels intersection 145 degrees:

$$K_1 = 1,084; K_2 = 1,05; K_3 = 1,067; K_4 = 1,114, \\ K_5 = 1,067; K_6 = 1,125.$$

The average value of the coefficient:

$$\frac{1,084 + 1,05 + 1,067 + 1,114 + 1,067 + 1,125}{6} = 1,084$$

- for a die with the angle of channels intersection 155 degrees:

$$K_1 = 1,069; K_2 = 1,047; K_3 = 1,04; K_4 = 1,085, \\ K_5 = 1,032; K_6 = 1,062.$$

The average value of the coefficient:

$$\frac{1,069 + 1,047 + 1,04 + 1,085 + 1,032 + 1,062}{6} = 1,056$$

Thus, the formula of Gubkin for calculation of the broadening in the process «rolling-pressing», will have the following form:

$$\Delta b = K \left(1 + \frac{\Delta h}{h_0} \right) \left(f_Y \cdot l_d - \frac{\Delta h}{2} \right) \frac{\Delta h}{h_0} \quad (7)$$

where K - coefficient taking into account the influence of backpressure in the die (Fig. 5).

CONCLUSIONS

The obtained formula (7) allows to find the value of the broadening arising from the implementation of the combined process “rolling-pressing”, when using an equal-channel step die. Moreover, this formula is applicable for any value of the angle of the channels intersection. For this purpose, it is necessary to substitute in formula (7), as coefficient K, the value defined in Fig. 5, depending on the desired angle of channels intersection. In Fig. 5 one can find the value of K for values of the angle of channels intersection of 135 - 155 degrees. Values of the coefficient K for angles of channels intersection lying outside this interval should be found using extrapolation.

REFERENCES

1. A.R. Fastikovskiy, V.N. Peretyatko, High schools. Ferrous metallurgy, 2, 2002, 15-17, (in Russian).
2. A.B. Naizabekov, S.N. Lezhnev, E.A. Panin, High schools. Ferrous metallurgy, 6, 2008, 22-26, (in Russian).
3. A.B. Naizabekov, S.N. Lezhnev, E.A. Panin, Technology of production of metals and recycled materials, 1, 2007, 116-122, (in Russian).
4. A.P. Grudev, Theory of rolling, M., Metallurgy, 2001, pp. 125-134, (in Russian).