

STUDY OF AXIAL FORCES WITH THE PURPOSE TO REALIZE A COMBINED PROCESS «HELICAL ROLLING-PRESSING»

Abdrakhman Naizabekov¹, Vitaly Talmazan², Alexander Arbuz³,
Toncho Koinov⁴, Sergey Lezhnev²

¹ Rudny Industrial Institute, Rudny, Republic of Kazakhstan

² Karaganda State Industrial University,

Temirtau, Republic of Kazakhstan,

E-mail: sergey_legnev@mail.ru

³ Kazakh National University named after Al-Farabi, Almaty

⁴ Department of Physical Metallurgy and Thermal Equipment,

University of Chemical Technology and Metallurgy,

8 Kl. Ohridski, 1756 Sofia, Bulgaria

E-mail: toni309@koinov.com

Received 19 January 2015

Accepted 27 February 2015

ABSTRACT

The key factor for practical realization of the combined process «helical rolling-pressing» is the axial force of the helical rolling, which should provide a continuous pressing in the matrix after the rolls. For the measurement of the maximum axial rolling force, which is actually the reserve of friction forces, a special strain gauge has been made. The work was carried out at a three-roll helical rolling mill “10-30” for the case of hot rolling of steel bars with diameters of 16 - 25 mm at a reduction of 6 % of diameter and a temperature of 1000°C. The results shown are of 24 tests.

Keywords: helical rolling, axial force, strain gauge, combined process.

INTRODUCTION

The usage of ultrafine-grain (UFG) and nanostructured (NS) metals and alloys as constructional and functional materials of the new generation promises huge advantages due to their properties. Different ways to obtain such materials with the use of intensive plastic deformation have been developed [1-2]. However, the industrial production of UFG and NS materials is still often interlinked with high expenditures of time and energy, restrictions of sizes, and, as a whole, low adaptability to manufacturing that reflects in their cost. Therefore, the development of new principles for using severe plastic deformation (SPD) for production of volumetric NS metals with perspective properties is an actual target.

It is feasible to remove restrictions on the length of a blank piece and provide process continuity with a probable combination of a continuous process (for example, rolling) and an equal channel angular pressing (ECAP) into one process. The theoretical substantiation

and practical realization of the combined process on the basis of longitudinal rolling in smooth rolls and an equal channel angular echelon matrix [2] were made in works [3 - 6]. Results of these works have revealed the prospectivity for creation of such combined processes.

It is known that during the helical rolling, owing to trajectory and speed features of the metal flow, the formation of UFG structure is also possible. However, owing to the same features the central part of the bar can remain not treated [7]. The combination of helical rolling and ECA pressing can eliminate this problem, thus providing the continuity of the process and a potentially better treatment of the structure, during the pass in comparison to the above described combined process. This idea is described in details in [8], however its realization is interlinked with difficulties of practical nature, caused by the complexity of the helical rolling process. The key factor is the value of the maximum axial force (that is, essentially, the reserve of friction forces) during helical rolling, which should be sufficient

for maintenance of continuous pressing in the matrix standing after the mill. Thus, owing to complexity of the process, experimental research of axial force maximum values distribution have high value for designing of the combined installation, with the purpose of accounting for the total influence of random factors, that is the very aim of this work.

The object in view is reached by the consecutive solution of following issues: experiment definition, designing and manufacturing of the measuring equipment, carrying out of the experiment and processing of its results.

EXPERIMENTAL

Measurements of axial force during helical rolling were repeatedly made by various authors [9 - 10] for the case of a pipe blank piece piercing into the sleeve and had the target of the optimization of the mandrel form and the piercing process as a whole. However, measurements of the arising axial force for the case of full compulsory braking of the bar in mill rolls of this type, have not been carried out.

For assessment of the demanded data about the maximum axial effort, a decision was made regarding carrying out of the experiment in 3 sequences with 8 experiments in each, with one influencing factor - the ratio between rolls diameter (D_v) and the diameter of blank piece (D_0), accordingly using different values of the factor for each sequence. Such assessment will allow to collect the statistical material for estimation of the maximum axial force, along all the product mix of the mill. Besides this, the use of a relative indicator (D_v/D_0) as the factor will allow the expansion of the database of experimental data in the future at the expense of experiments for other mills with the same type of calibration and adjustment of rolls.

The experiment was carried out at the mill of radial-displacement rolling (RDR) "10-30", designed by

National Research Technological University "Moscow Institute of Steel and Alloys" (Russia), as the one providing the demanded structure of the bar after rolling [7, 11]. For the experiment initial profiles with diameters: 16 mm, 20 mm and 25 mm, as the most typical for mill product mix, have been chosen. The ratio between the diameter of the conical rolls (71 mm) and the diameter of the blank piece (D_v/D_0), as well as the initial (D_0) and the final dimensions (D_1) of bars, by sequences of experiments, are given in Table 1.

The percentage reduction (ϵ , %) for all cases is assumed to be constant, and equal to 6 % of diameter, as convenient for mill adjustment, as well as due to the fear of possible damaging of rolls and camp structure under high load.

Round hot rolled bars (GOST 2590-88) with length of 300 mm were used as blank pieces for the experiment, with diameters according to Table 1. Steel grade St3 (0,14 - 0,22 % C) as one of the most globally widespread constructional material was chosen as the material for blank pieces. The temperature of the bars heating up was defined at the level of 1000°C, which was the average value of the temperature for heat treatment of this class of steel. The distance from the deformation region to the measuring plate corresponded to the prospective distance to the matrix during the combined process and was equal to 100 mm.

The scheme for carrying out of the experiment for measurement of the maximum axial force is shown on Fig. 1. The methodology of the experiment is as follows. Bars for experiments with length of 300 mm, with diameters according to Table 1, in sets of 2 pieces are loaded into the tubular furnace, warmed up to 1000°C with staying of 16 - 30 minutes, depending on the section and arrangement of the blank pieces. After this, the bars in turns are put into the mill rolls. In the process of rolling the bar (1), moving forward, touches the measuring plate (3) with fixed edges and bends it elastically, under the influence of axial force (F). Plate deformation

Table 1. Ratio values by sequences of experiments.

Sequence of experiments	D_v/D_0	D_0 , mm	D_1 , mm	Number of experiments
I	2,8	25	23,5	8
II	3,6	20	18,8	8
III	4,4	16	15	8

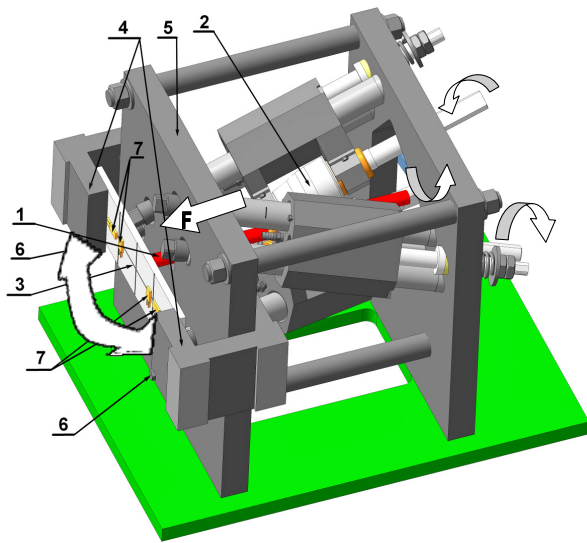

Fig. 1. Scheme of maximum axial force measurement carrying out. (1 - bar; 2 – rolls, 3 - measuring plates, 4 – brackets, 5 – frame, 6 - adjusting bolts, 7 - resistive strain sensors, F - axial force).

is perceived by resistive strain sensors (7) pasted on it and registered by a strain sensor station in the form of an effort schedule. The peak value of the loading is registered in the table of results.

In addition to the mill RDR “10-30”, the equipment involved in the experiment, includes the following: a tubular furnace Nabertherm R120/1000/13 (Nabertherm GmbH, Germany); a strain sensor station ZET-017-T8 (“ETMS” CJSC, Russia); a measuring plate with resistive strain gauge sensors TKFO1-2-200 (“ETMS” CJSC, Russia); a laptop for control of the strain sensor station and signals recording.

The use of a plate with fixed edges (beam scheme) as a measurement device, is caused by the features of the mill design, which is not intended for piercing of blank pieces, and therefore is complicated, unlike in the application of ready decisions (serial load cells) [9-11]. Besides this, such a scheme was chosen owing to the greatest linearity of measurements, less dependence on the point of force application [13], better security of the resistive strain sensors, both from temperature and from mechanical damages, simplicity and convenience of realization. The steel 5XB2C (alloyed spring steel) after tempering was chosen as the material of the measuring plate, as capable to endure considerable elastic deformation. The dimensions of the plate were calculated with a condition for achievement of deformation in the places

of the resistive strain gauge sensors pasting, equal to the maximum admissible deformation of chosen resistive strain gauge sensors (2 %) after the force of 100 kN that is more than 2.5 times greater than the expected peak force. Plate edges, realising the beam scheme, lean against thick-wall brackets (4), connected to the front frame of the rolling mill adjusting bolts (6).

Thus, the measuring plate with four resistive strain gauge sensors, connected into the bridge scheme and providing thermal compensation, was developed and manufactured. Resistive strain gauge sensors were pasted using a special glue Z70 (Hottinger Baldwin Messtechnik GmbH, Germany). The scheme of pasting and connection of the resistive strain gauge sensors is shown on Fig. 2.

Resistive strain sensors are pasted symmetrically in the middle of the distance between the centre of plate and support points. Measuring (active) resistive strain sensors (R^A) are pasted along the plate, compensatory sensors (R^K) - across it, thus perceiving only the temperature disturbance. During the connection into the bridge scheme, measuring (R^A) and compensatory (R^K) elements alternate. Such connection provides the increase

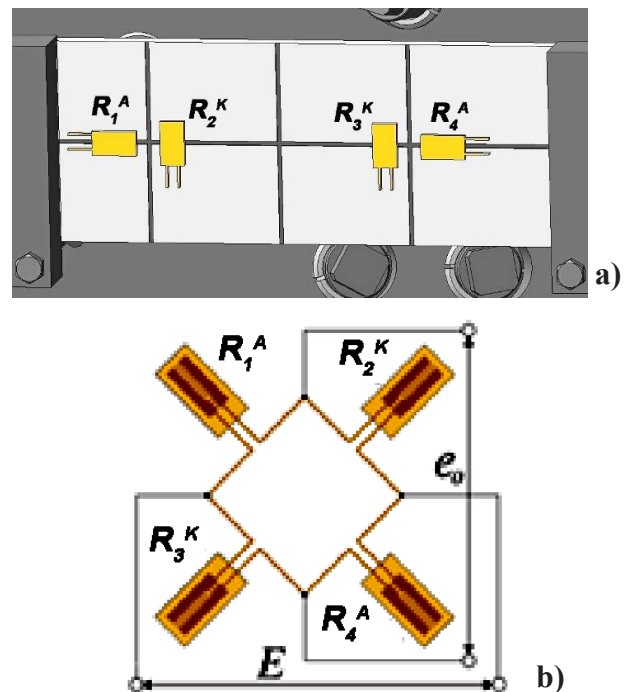

Fig. 2. Scheme of resistive strain gauge sensors pasting and connection to the measuring plate. a) Scheme of resistive strain gauge sensors pasting; b) Scheme of resistive strain gauge sensors connection (E - feeding of bridge; e_0 - output voltage).

in sensitivity of the scheme during its protection against temperature distortions [13]. The scheme receives a feed of 5V direct current from the strain sensor station. Signal recording is made with frequency of digitization of 1 kHz. The measuring plate was calibrated at the torsion and tensile testing machine MI-40KU (Ukraine) in a mode of compression testing, as per methodology, minimizing the influence of the hysteresis. The essence of calibration is the composition of the dependence connecting the electric voltage in the scheme and the bending force, applied to the plate. This dependence should have a linear character. For carrying out of the calibration the plate was consistently loaded with force with the step of 5 kN in a range from zero to 35 kN. The corresponding values of the voltage in the scheme under loading and after its removal, were fixed. With the view of hysteresis reduction and accuracy increase, 3 passes on the specified range of forces – upwards, downwards and upwards were carried out, or 42 measurements in total (including measurements of zero values).

The data received in the process of calibration tests were statistically processed, and a regression equation was developed on their basis, connecting the force applied to the plate (F_i , N) with the voltage (U_i , mV) in the scheme. The equation looks like: $F_i = -3631.2 U_i + 10122$. The ratio of determination $R^2 = 0.99998$; the standard error of measurements attributed to the value of the working range of plate measurements (40 kN) based on results from 42 tests was less than 0.2 %. The received data were uploaded into the program of measurements registration and processing of the strain sensor station ZET-017-T8 for the possibility of signal recording in the form of the force trend. After the experiment little random control loadings were made, in which the deviation of values did not exceed the value specified above, which confirmed the accuracy and the stability of the work of the measuring plate.

RESULTS AND DISCUSSION

All steps of the experiment have passed in the normal mode. At the moment of the visible bend achievement of the bar resting against the plate, the mill drive engines were synchronously stopped to make possible the taking out of the bar from the stand without interfering with mill settings. The general view of the experimental installation and the bar, taken out after rolling, are shown on Fig. 3. On Fig 3a the bend of the measuring plate under the influence of the axial force is clearly seen. On Fig. 3b in the bottom part of the bar there are roll marks seen, characterizing the deformations region.

Force trends fixed by the strain sensor station are generally similar and have the same distinctive sections. As an illustration of this, Fig. 4 shows the trends of tests II-3 and II-6, fixed by strain sensor station. At the first section there is a sharp (during approximately 0.15 sec) increasing of the force, with some delay closer to the peak. At this stage, there is a bend of the plate under the influence of axial movement of the bar and a small

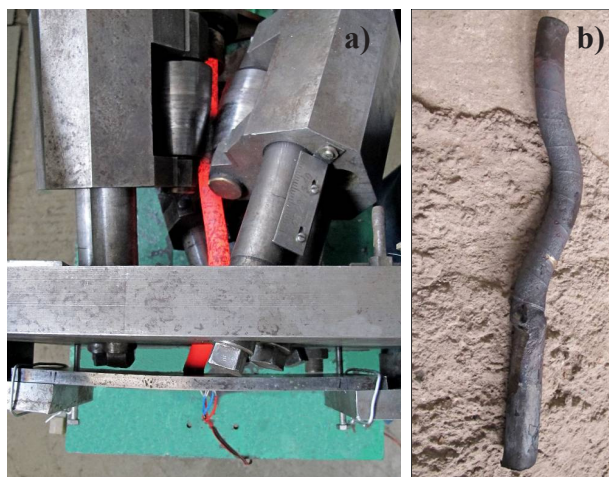

Fig. 3. Carrying out of the experiment. a) carrying out of the experiment (moment of rolls stoppage); b) bar after the test I-7.

Table 2. Statistical characteristics of experiments.

Statistical parameter	Experiments sequence/ (D_v/D_0)		
	I / 2,8	II / 3,6	III / 4,4
F_{ave} , N	35 541	31 098	20 539
F_{max} , N	39 394	34 484	21 753
F_{min} , N	31 077	27 718	19 512
F_{st} , N	2 402	2 424	787

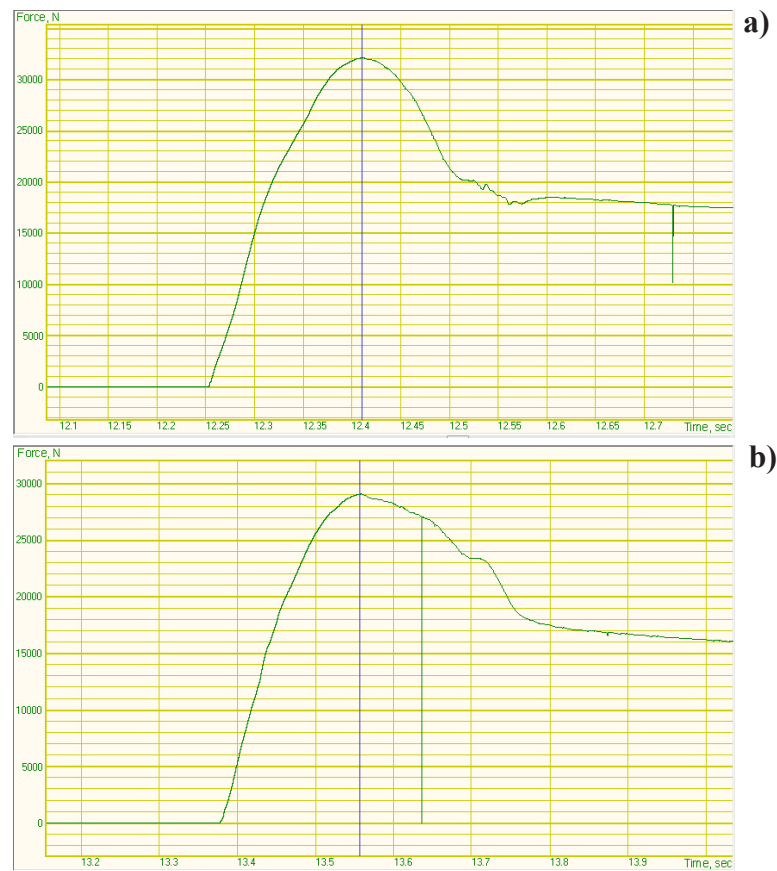

Fig. 4. Force trends for tests II-3 (a) and II-6 (b).

deformation of the head end of the bar. The shape of this section of the trend comes close to a parabola shape. Then there is a bend of the bar, accompanied by decreasing of the force by one third and a smooth alignment of the force decreasing, probably connected with the start of rolls sliding. Thus, it is important to notice, that at the last stage, the bar leans not only against the plate, but also against the part of the front frame, because at this stage it is generally strongly bent.

The moment of the stoppage of the drives is clearly visible at the trends in the form of a short negative spike to the right of the peak. As it was shown by the experiments, the moment of the drives stoppage does not influence the qualitative and the quantitative picture of the force changing in practice. The results of each sequence of experiments have been checked for presence of gross errors by Student's t-test, and then statistical characteristics have been calculated for each sequence: arithmetic average (F_{ave}), maximum (F_{max}) and minimum (F_{min}) values, standard deviation (F_{st}). The listed characteristics are shown in Table 2. Values of the force in all experiments are shown graphically on Fig. 5.

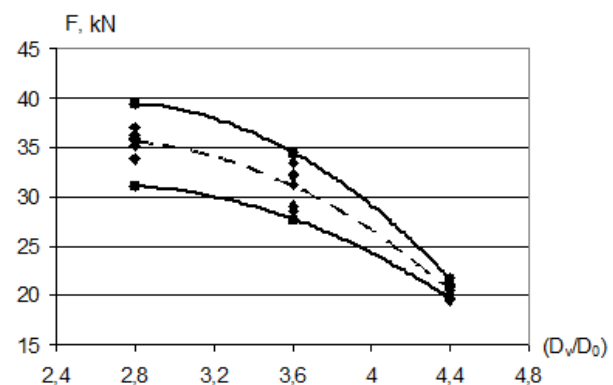

Fig. 5. Values of maximum axial force.

CONCLUSIONS

The equation $F = -4,78(D_v/D_0)^2 + 25,05(D_v/D_0) + 2,89$, characterizing the dependence of maximum axial force at helical rolling from the ratio between the rolls diameter and the diameter of blank piece with constant reduction $\varepsilon = 6\%$ (shown in dotted line) has been obtained. The ratio of determination was equal to $R^2 = 0.92$.

From the data it is possible to draw the conclusion that during the rolling of thicker profiles essentially a high disorder of values of forces is observed, that can be possibly explained by the increased influence of the following factors - features of internal and contact friction at the blank piece, its rheology, features of the deforming tool calibration.

The measured values of the axial force (up to 38 kN) evidence the principal possibility of the combined process of rolling-pressing realization with high values of the angles at the joint of the channels of the ECA-matrix (140° - 150°). It was established that after reaching of the force peak, there is a blank piece bend, thus, during the realization of the combined process, the main danger here is not in the lack of force, but in the possibility of a blank piece bend between the rolls and the matrix. Besides that, the value of the force can be raised a little by using of notched rolls at maximum reduction. The obtained results are comparable to results of research on similar profiles piercing forces on three-roll mills [9 - 10].

The results of this study can be used for the optimization of the process of continuous blank pieces piercing into the sleeve, and as results containing data on the reserve of axial force (friction forces) of the helical rolling.

REFERENCES

1. R.Z. Valiev, I.V. Alexandrov, Volumetric nano-structural metal materials: receiving, structure and properties. Monography, Moskow, Akademkniga, 2007, (in Russian).
2. Zh.A. Ashkeev, A.B. Naizabekov, S.N. Lezhnev, A.R. Toleuova, Billet deformation in uniform-channel stepped die, *Steel in Translation*, 35, 2, 2005, 37-39.
3. S.N. Lezhnev, A.B. Naizabekov, Y.A. Panin, 20th Anniversary International Conference on Metallurgy and Materials, *Metal 2011*, May 18-20, 2011, Brno, Czech Republic, 272-277.
4. A.B. Naizabekov, S.N. Lezhnev, E.A. Panin, 17-th International Conference on Metallurgy and Materials, *Metal 2008*, May 13-15, 2008, Hradec nad Moravici, Czech Republic.
5. Patent of the Republic of Kazakhstan #25863. MIIK B21J 5/00. The device for continuous metal pressing. A.B. Naizabekov, S.N. Lezhnev, E.A. Panin, 2013, Applicant and patent owner - Regional state enterprise "Karaganda State Industrial University". - № 2011/0762.1, applied 02.07.2011; published 15.02.2013, *Bulletin of inventors*, 2013, #7, (in Russian).
6. S. Lezhnev, E. Panin, I. Volokitina, Research of combined process "Rolling-pressing" influence on the microstructure and mechanical properties of aluminium, *Advanced Materials Research*, volume 814, 2013, 68-75.
7. S.P. Galkin, Trajectory and speed features of radial-displacement and screw rolling, *Modern problems of metallurgy*, Dnepropetrovsk, *Sistemni tehnologii*, 11, 2008, 26-33, (in Russian).
8. A. Naizabekov, S. Lezhnev, A. Arbut, 22nd International Conference on Metallurgy and Materials, *Metal 2013*, May 15-17, 2013, Brno, Czech Republic, 422-426.
9. P.K. Teterin, The theory of cross-sectional and screw rolling, 2nd ed., Moskow, Metallurgy, 1983, (in Russian).
10. D.A. Kovalev, PhD thesis, The research and development of the technology for helical rolling process for increase of plasticity hypereutectic silumin alloys, Moskow, 2011, (in Russian).
11. Patent #2009737 of the Russian Federation, MPK⁵ B21B19/02. The three-roll mill for screw rolling and the technological tools for screw rolling mill, B.A. Romantsev, V.K. Mihailov, S.P. Galkin, M.G. Degtyaryov, B.V. Karpov, A.P. Tchistova, № 5031365/27; applied 13.02.1992, published 30.03.1994, (in Russian).
12. Patent #2293619 of the Russian Federation, MPK B21B 19/00, The method of screw rolling, S.P. Galkin, Applicant and patent owner - National Research Technological University "Moscow Institute of Steel and Alloys" - #2006110612/02, applied 04.04.2006; published 20.02.2007. *Bulletin of inventors*, 2007, #5. page 46, (in Russian).
13. R.A. Makarov, L.B. Rensky, Tenzometry in mechanical engineering, Moskow, Mechanical engineering, 1975, (in Russian).